



**SCHEDA TECNICA**      **DATENBLATT**      \* = PAG. 202      **SPRING 700 TN BIG**  
**DATASHEET**      **DONNÉES TECHNIQUE**      ⇨ = RIF. UCR

MODELLO	MODELL		2	3	4
MODEL	MODÈLE		-2/+7 °C	-2/+7 °C	-2/+7 °C
VOLUME INTERNO	INTERNER RAUM	dm <sup>3</sup>	168	252	336
INTERNAL VOLUME	VOLUME INTERNE				
DIMENSIONI INTERNE UTILI	NUTZLICHE INTERNE ABMESSUNGEN	MM	360x567x608 x2	360x567x608 x3	360x567x608 x4
USEFUL INTERNAL DIMENSIONS	DIMENSION INTERNE UTILIES	LxPxH			
COMPRESSORE	KOMPRESSOR		EMBRACO	EMBRACO	EMBRACO
COMPRESSOR	COMPRESSEUR		EMT6165GK	EMT6165GK	EMT6165GK
POTENZA FRIGORIFERA	KALTELEISTUNG	W	545 (-10/+45)	545 (-10/+45)	545 (-10/+45)
REFRIGERATION POWER	UISSANCE FRIGORIFIQUE				
POTENZA ASSORBITA	LEISTUNGS-AUFNAHME	W	275 (-10/+45)	275 (-10/+45)	275 (-10/+45)
ABSORBED POWER	PUISSANCE ASSORBEE				
MASSIMA CORRENTE	MAX STROMAUFNAHME	A	5.22	5.22	5.22
MAX CURRENT	COURANT MAXIMUM				
TENSIONE E FREQUENZA	NETZSPANNUNG UND FREQUENZ	V / Hz	230 / 50	230 / 50	230 / 50
VOLTAGE & FREQUENCY	TENSION ET FREQUENCE				
PESO NETTO	REINGEWICHT	KG	110	120	130
NET WEIGHT	POIDS NET				
RUMORE	LAUTSTARKE	DB			
NOISE	BRUIT	5 M			
RIPIANI MASSIMI	MAX REGALE	N°	20 GN1/1 H40	30 GN1/1 H40	40 GN1/1 H40
MAX SHELVES	NIVEAUX MAXIMUM				
GAS REFRIGERANTE	KALTEMITTEL	GR	250 - R404A	250 - R404A	250 - R404A
REFRIGERANT GAS	GAS FRIGORIGENE				
ELETTRONICA	ELEKTRONISCHES STEUERGEHAUSE		EVCO	EVCO	EVCO
ELECTRONIC CARD	CENTRALE ELECTRONIQUE		EVX	EVX	EVX
CLASSE CLIMATICA	KLIMATISCHE KLASSE	INDEX	5	5	5
CLIMATIC CLASS	CLASSE CLIMATIQUE		40°C - 40%HR	40°C - 40%HR	40°C - 40%HR
CLASSE ENERGETICA	ENERGIEEFFIZIENZKLASSE	INDEX			
ENERGY CLASS	CLASSE ENERGETIQUE				
CONSUMO ENERGIA 24H	24H STROMVERBRAUCH	KW			
24H ENERGY CONSUMPTION	CONSOMMATION 24H D'ÉNERGIE				
CONSUMO ENERGIA ANNUO	DER JAHRliche ENERGIEVERBRAUCH	KW			
YEAR ENERGY CONSUMPTION	CONSOMMATION ANNUELLE D'ÉNERGIE				
DIMENSIONI IMBALLO	AMBENSUGGEN VERPACKUNG	MM	INC 1360x760x970	INC 1840x760x970	INC 2320x760x970
PACKING DIMENSIONS	DIMENSIONS EMBALLAGE	LxPxH	REM 1220x760x970 without splashback	REM 1700x760x970 without splashback	REM 2180x760x970 without splashback
RESA ABBATTIMENTO	ERGIEBIGKEIT SCHNELLKUHlung	KG			
CHILLING PERFORMANCE	REndEMENT REFROIDISSEMENT				
RESA SURGELAZIONE	ERGIEBIGKEIT SCHOckFROSTUNG	KG			
FREeZING PERFORMANCE	REndEMENT CONGELATION				
VASCHETTE GELATO	EISBECHER	5L			
ICE CREAM PANS	BOL DE GLACE	(165x360xH120)			

Dati tecnici soggetti a modifiche senza preavviso.

All specification subject to change without notice.

Technische Daten und Eigenschaften mit Änderungen ohne Anzeige.

Caractéristiques techniques sujettes à modification sans avis.

	L1	L2
2-	1300	1160
3-	1780	1640
4-	2260	2120

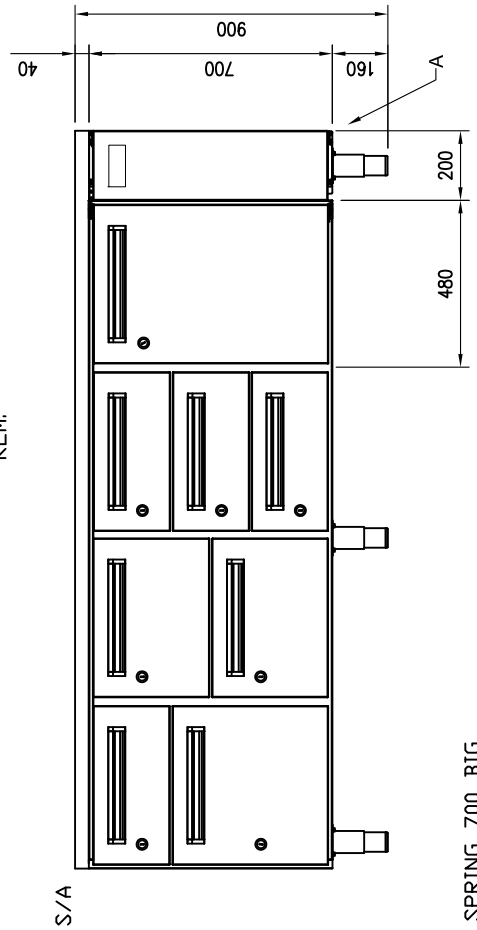
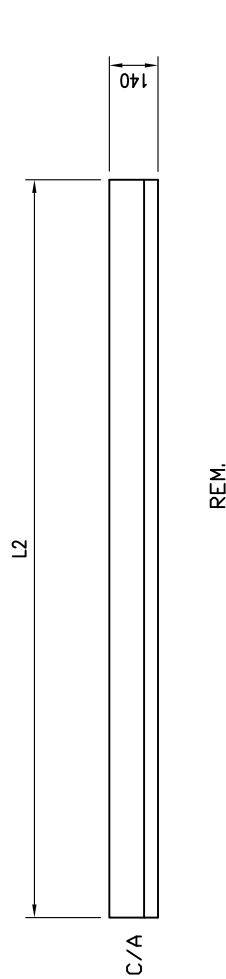
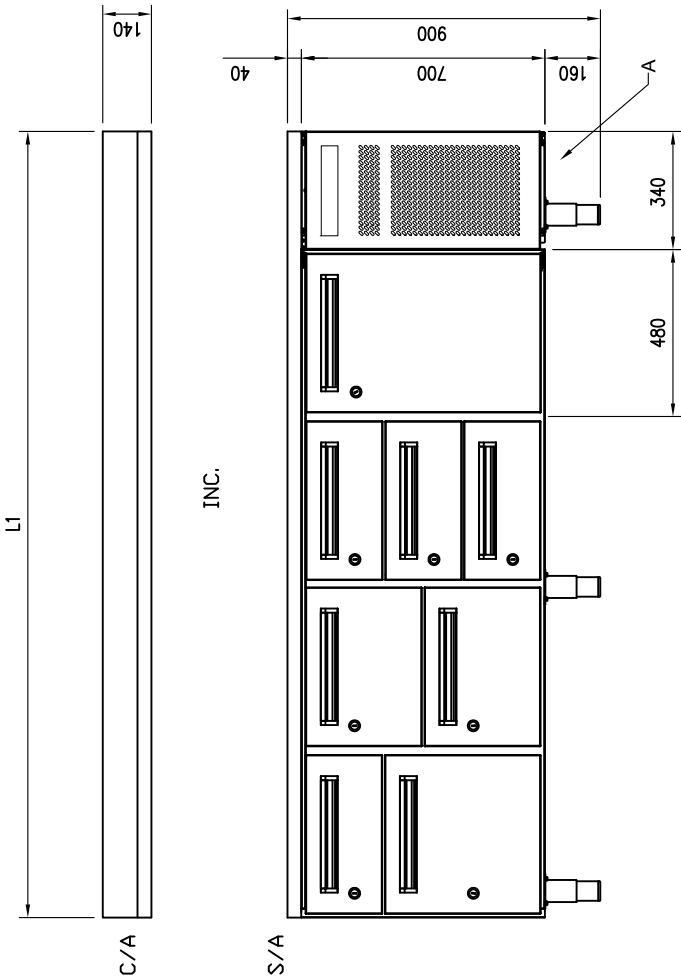
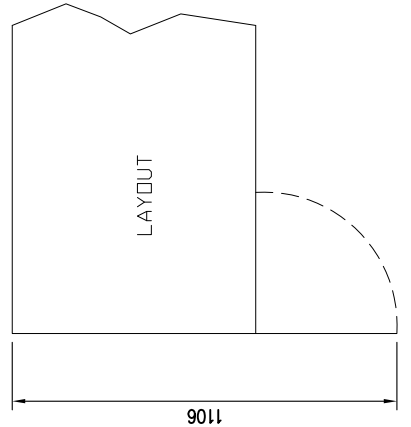
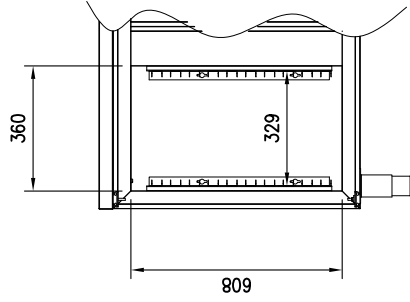
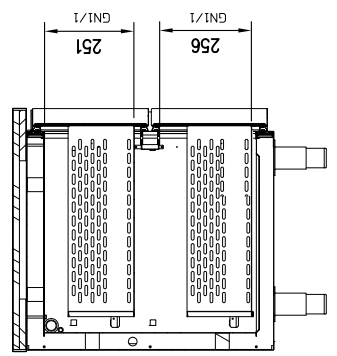
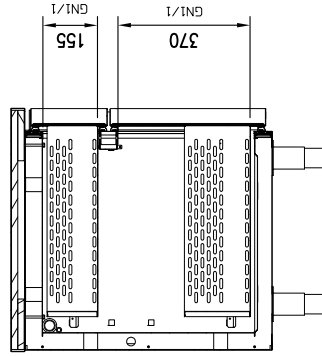
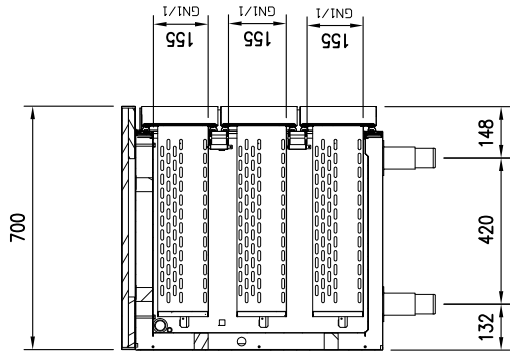

SPRING 700 BIG  
 A= ELECTRICAL CONNECTION  
 INSULATION THICKNESS 60 MM

## **BLAST CHILLERS & FREEZERS ADVISE**

### **IT**

Le rese in abbattimento e in surgelazione espresse in Kg sono indicative e non vincolanti.

Il tempo di raffreddamento degli alimenti dipende dalla loro composizione e dimensione.

**Il tempo di raffreddamento reale dei vari alimenti, potrebbe essere diverso da quello indicato.**

### **EN**

The output chilling & freezing expressed in Kg are indicative and not binding.

The cooling time of food depends on their composition and size.

**The actual cooling time of the various foods, may be different from the one indicated.**

### **DE**

Die in Kgs angegebenen Ergiebigkeiten von Schnellkuhlung und Schockfrostung sind indikativ und nicht verbindlich.

Die Abkühlzeit von Lebensmitteln hängt von ihrer Zusammensetzung und Größe ab.

**Die Kühlzeit der tatsächlichen verschiedenen Lebensmitteln, kann sich von dem hier angegebenen Werten unterscheiden.**

### **FR**

Les resultats de refroidissement et de congélation exprimés en Kg sont à titre indicatif et non contraignant.

Le temps de refroidissement des aliments dépends de leur composition et de la dimension.

**Le temps de refroidissement réel des différents aliments, pourrait être différent de celui indiqué.**

## **UPRIGHT CABINETS & COUNTERS ADVISE**

### **IT**

I consumi di energia espressi in Kwh sono riferiti alla norma europea EN16825.

Il consumo dipende da come viene usata la macchina e dal luogo di installazione.

**Il consumo di energia reale, potrebbe essere diverso da quello indicato.**

### **EN**

Energy consumption expressed in kWh are according to European standard EN16825.

The consumption depends on how the machine is used and the place of installation.

**The actual energy consumption, may be different from the one indicated.**

### **DE**

Energieverbrauch in kWh ausgedrückt werden, der europäischen Norm EN16825 bezeichnet.

Der Verbrauch hängt ab, wie die Maschine benutzt wird und wo sie installiert wird.

**Der tatsächliche Energieverbrauch, kann sich von dem hier angegebenen Werten unterscheiden.**

### **FR**

La consommation d'énergie exprimée en kWh sont appelés à la norme européenne EN16825.

La consommation dépend de la façon dont la machine est utilisée et le lieu d'installation.

**La consommation d'énergie réelle, peut être différente de celle indiquée.**